

AD-D96 Series 5 User Guide

revised 041212 for units shipped after 030112

Protecting Against Electrostatic Discharge – Static electricity can harm delicate components on the AD-D96 board. To prevent static damage, discharge static electricity from your body before you touch any jumpers or switches with the cover removed. You can do so by touching an unpainted metal surface.

Clocks – The AD-D96 should have only one clock source. If running with the internal clock, make sure SW2 is in the INT position and no external clock is connected.

Sync Signals on the BNC connectors should conform to the AES-3id specification. AES-3, through an XLR-to-BNC transformer (Neutrik NADITBNC-F or equivalent) will work fine. S/PDIF may work, but is not specified.

Sync signals can be either AES or Word Clock (jumper selectable). AES sync should conform to the above specs. Output sample rate will match the sample rate of the applied external reference sync. The range is:

32KHz \pm 1%
 44.1KHz -1% to 48KHz +1%
 88.2KHz -1% to 96KHz +1%

DB25 Connectors conform to the Tascam pin out. Please note you can't use a pin to pin DB25 cable to connect the digital outputs to a DB25 digital input connector. A special cross cable is required.

HV-3D OL Peak LEDs are set to illuminate at +22 dBu, that is 2dB below the clipping point of the converter: (referenced to 0VU = -20dBFS). The analog electronics can handle greater than +30dBu.

Sample Rate can be set to 44.1k or 48k and doubled to 88.2k or 96k with the 1X/2X switch. This switch has no effect when the clock source is switched to external

Sample Rate kHz	Rear Panel	
44.1	X1	44
48	X1	48
88.2	X2	44
96	X2	48

Lock LED illuminates when the unit's clock is locked to the external sync input.

Clock In is normally terminated to 75 ohms. Remove jumper J8 if you are daisy chaining clocks. The last unit in the chain should be terminated.

Clock Out is a regenerated signal that removes any jitter that may be present at Clock In.

True-Lock-Clock – When set to External Clock, the AD-D96 will always revert to its internal clock in the event that something happens to the external reference. This way, if you lose external clock, you won't lose the recording.

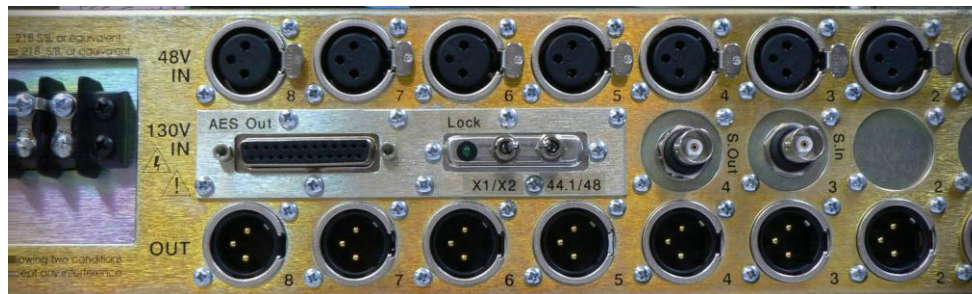

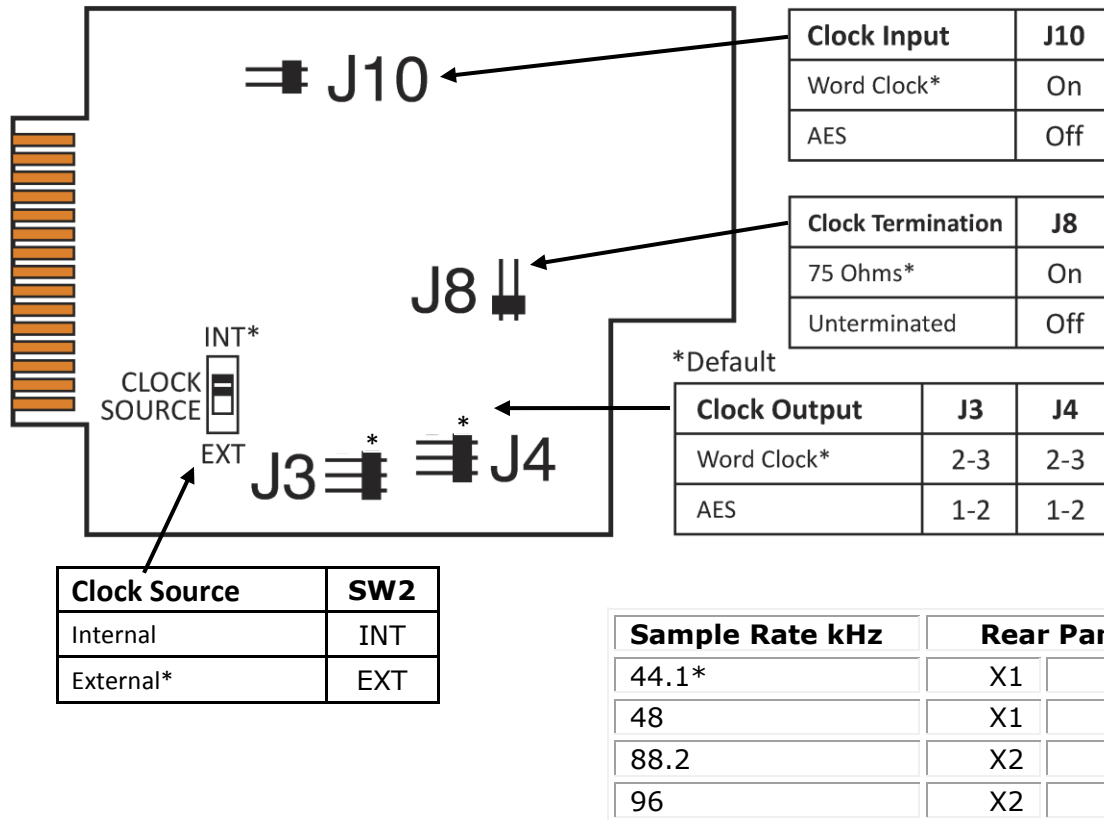

Access Jumpers by removing the cover from the HV-3D. The digital board has a diagram label showing the jumper setting and locations similar to the diagram on here.

FCC Notice Information for the User

- This equipment has been tested and found to comply with the limits for a Class A digital device, pursuant to part 15 of the FCC Rules. These limits are designed to provide reasonable protection against harmful interference when the equipment is operated in a commercial environment. This equipment generates, uses, and can radiate radio frequency energy and, if not installed and used in accordance with this instruction manual, may cause harmful interference to radio communications. Operation of this equipment in a residential area is likely to cause harmful interference in which case the user will be required to correct the interference at his or her own expense.

DB25 Connectors conform to the Tascam pin out. Please note you can't use a pin to pin DB25 cable to connect the digital outputs to a DB25 digital input connector. A special cross cable is required.

Tascam DB25 Wiring Charts

Analog Input Channel	1	2	3	4	5	6	7	8
+ Pins	24	10	21	7	18	4	15	1
- Pins	12	23	9	20	6	17	3	14
Gnd Pins	25	11	22	8	19	5	16	2

AES DB25	Digital Inputs (not used)				Digital Outputs			
Channel	1/2	3/4	5/6	7/8	1/2	3/4	5/6	7/8
+ Pins	24	10	21	7	18	4	15	1
- Pins	12	23	9	20	6	17	3	14
Gnd Pins	25	11	22	8	19	5	16	2